

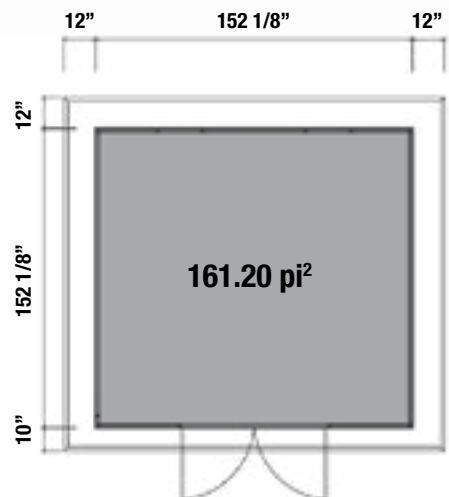

INSTALLATION INSTRUCTIONS
INSTRUCTIONS D'INSTALLATION



INSTALLATION INSTRUCTIONS AND RECOMMENDATIONS

- Remove all parts from the packaging and lay them out on a clean work surface in Zone I/II and III.
- Please read the list of components BEFORE assembly, making sure that no parts are damaged or missing.
- In the unlikely event you receive defective materials, the product warranty does not cover labor. Once you alter a board (cut, rip, rout, screw, etc.) it cannot be returned.
- Assemble all parts according to the instructions published by Fiberwood and do not skip any steps. Since Fiberwood's limited warranty does not apply to all conditions attributable to improper shed installation.
- For shed construction and handling, please use only the tools listed in the assembly instructions.
- Always wear work gloves, safety glasses, and any other type of long-sleeved clothing during shed assembly or any type of maintenance work.
- Treat wall panels with extreme care before and during assembly. Place them carefully on the ground.
- Avoid walking on them or placing objects on them.
- At least two people are required to assemble the shed.
- Allow sufficient space at the installation site outside the shed to access it from the outside during assembly.
- Do not install in cold or windy weather. Wind direction is an important factor that must be considered when placing the shed on your property. Choose a suitable location where there are no excessive winds to prevent high wind pressure on the doors.
- Due to the high proportion of composite material, the surface may have different color shades. This does not mean that special treatment is required or that it will affect the shed's lifespan.
- You need to get a tube of 100% transparent silicone sealant.

CARE, MAINTENANCE AND SAFETY INSTRUCTIONS











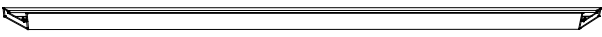

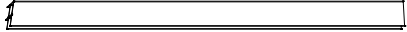











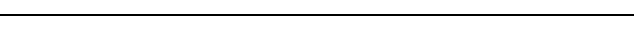

- ⚠ The shed is generally used for storing objects. The shed is not especially designed for residential purposes.
- ⚠ Regularly check the shed for stability and ensure that the shed location is level.
- ⚠ Be careful when handling parts with metal edges.
- ⚠ For the construction and handling of the shed, please only use tools that are listed in the assembly instructions.
- ⚠ Avoid using lawnmowers and mechanical scythe in the immediate vicinity of the shed.
- ⚠ To clean the shed, start by rinsing it with a garden hose to remove surface debris. Then you can use a soft-bristled brush with warm soapy water.
- ⚠ Do not damage, gouge, scrape or puncture any surface of the shed, using metal shovels or sharp-edge tools to remove snow and ice on any surface of the garden shed or in any other way. Instead, use a plastic shovel and recommended calcium chloride or rock salt to melt snow and ice.
- ⚠ Do not paint, stain or apply other coating materials or any other chemical substances, including detergents or pesticides to the shed.
- ⚠ Clean oil or grease spills as soon as possible and at the latest within seven days. Start by rinsing with a garden hose and use warm soapy water and a soft-bristled brush. If that's not enough, you can use recommended all-purpose cleaners, including for composite, and follow the manufacturer's instructions carefully.
- ⚠ Do not store any hot objects in the shed, such as recently used grills or blowtorches, or any volatile chemicals.
- ⚠ Do not lean heavy objects against the walls of the shed, as it could deform the entire structure.
- ⚠ Keep the roof free of snow and accumulated foliage. Large amounts of snow can damage the shed and make it dangerous for entering.
- ⚠ Ensure there is adequate ventilation in the shed to prevent excess moisture.
- ⚠ Always keep the doors closed and locked when the composite shed is not in use to avoid any kind of wind damage.
- ⚠ If there is mold present, you can use a garden hose and warm soapy water with a soft-bristled brush. If that's not enough, you can use recommended cleaners, including for mold, and follow the manufacturer's instructions carefully.
- ⚠ Avoid direct water projection from an automatic watering system onto the composite boards or other parts of the shed, as this water could cause stains where it hits the surface.



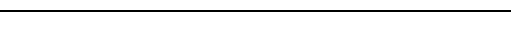





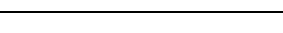





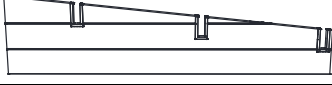











INSTRUCTIONS ET RECOMMANDATIONS D'INSTALLATION

- Retirez toutes les pièces de l'emballage et étalez-les sur une surface de travail propre en zone I/II et III.
- Veuillez lire la liste des composantes AVANT l'assemblage, assurez-vous qu'aucune pièce n'est endommagée ou manquante.
- Dans le cas improbable où vous recevez des matériaux défectueux, notez que la garantie sur les produits ne couvre pas les frais de main-d'œuvre. Une fois que vous avez altéré le produit (p.ex., en le coupant, le refendant, le toupillant ou le vissant), vous ne pouvez plus le retourner.
- Assemblez toutes les pièces conformément aux instructions publiées par Fiberwood et ne sautez aucune étape. Étant donné que la garantie limitée de Fiberwood ne s'applique pas à toutes les conditions attribuables à une mauvaise installation du cabanon.
- Pour la construction et la manipulation du cabanon, veuillez utiliser uniquement les outils répertoriés dans les instructions de montage.
- Portez toujours des gants de travail, des lunettes de sécurité et tout autre type de vêtements à manches longues lors de l'assemblage du cabanon ou de tout type de travaux d'entretien.
- Traitez les panneaux muraux avec un soin extrême avant et pendant le montage. Placez-les soigneusement sur le sol.
- Évitez de marcher dessus ou de placer des objets dessus.
- Au moins deux personnes sont nécessaires pour assembler le cabanon.
- Laissez suffisamment d'espace sur le site d'installation à l'extérieur du cabanon pour pouvoir y accéder de l'extérieur lors de l'assemblage.
- Ne pas installer par temps froid ou venteux. La direction du vent est un facteur important qui doit être pris en compte lors de la mise en place du cabanon sur votre terrain. Choisissez un endroit adéquat là où il n'y aurait pas de vents excessifs afin d'éviter qu'il y ait une pression trop forte de vent élevé sur les portes.
- En raison de la forte proportion de matériel en composite, la surface peut avoir différentes nuances de couleur. Ceci ne signifie pas qu'un traitement spécial est nécessaire ou que cela affectera la durée de vie du cabanon.
- Vous devez vous procurer un tube de scellant 100% silicone transparent.

INSTRUCTIONS D'UTILISATION, D'ENTRETIEN ET DE SÉCURITÉ

- ⚠ Le cabanon est généralement utilisé pour ranger des objets. Il n'est pas spécialement conçu à des fins résidentielles.
- ⚠ Vérifiez régulièrement la stabilité du cabanon et assurez-vous que l'emplacement du cabanon est de niveau.
- ⚠ Soyez prudent lorsque vous manipulez des pièces avec des bords en métal.
- ⚠ Évitez d'utiliser des tondeuses à gazon et des faux mécaniques à proximité immédiate du cabanon.
- ⚠ Pour nettoyer le cabanon, commencez par le rincer avec un boyau d'arrosage pour éliminer les débris de surface. Ensuite vous pouvez utiliser une brosse à poils souples avec de l'eau savonneuse tiède.
- ⚠ Ne pas endommager, entailler, gratter ou perforer toute surface du cabanon, en utilisant une pelle à métal ou des outils à bords tranchants pour enlever la neige ou de la glace sur toute surface de celui-ci, ou de toute autre manière. Utilisez plutôt une pelle en plastique et du chlorure de calcium ou du sel gemme recommandé pour faire fondre la neige et la glace.
- ⚠ N'appliquez pas de peinture, de teinture ou d'autres matériaux de revêtement ni toute substance chimique, y compris des nettoyeurs ou des pesticides sur le cabanon.
- ⚠ Nettoyez le plus rapidement possible et au plus tard dans les sept jours les taches laissées par des déversements d'huile ou de graisse. Commencez par rincer avec un boyau d'arrosage et utilisez de l'eau tiède savonneuse et une brosse à poils souples. Si cela n'est pas suffisant, vous pouvez utiliser des nettoyeurs recommandés tout usage, incluant pour le composite, et suivre attentivement les instructions du fabricant.
- ⚠ Ne rangez pas d'objets chauds dans le cabanon, tels que des grils ou des chalumeaux récemment utilisés, ou des produits chimiques volatils.
- ⚠ N'appuyez pas d'objets lourds contre les murs du cabanon, car cela pourrait déformer l'ensemble de celui-ci.
- ⚠ Gardez le toit exempt du surplus de neige et de feuillage accumulé. De grandes quantités de neige peuvent endommager le cabanon en composite et rendre son accès dangereux.
- ⚠ Assurez-vous qu'il y a une ventilation suffisante dans le cabanon afin d'éviter un excès d'humidité.
- ⚠ Gardez toujours les portes fermées et verrouillées lorsque le cabanon n'est pas utilisé pour éviter tout type de dommages causés par le vent.
- ⚠ Si de la moisissure est présente, vous pouvez utiliser un boyau d'arrosage et de l'eau tiède savonneuse, avec une brosse à poils souples. Si cela n'est pas suffisant, vous pouvez utiliser des nettoyeurs recommandés, incluant pour la moisissure, et suivre attentivement les instructions du fabricant.
- ⚠ Évitez la projection d'eau d'un système d'arrosage automatique directement sur les planches de composites ou les autres pièces du cabanon puisque cette eau peut occasionner des tâches là où elle frappe la surface.

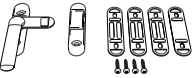









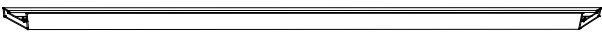

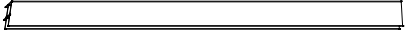











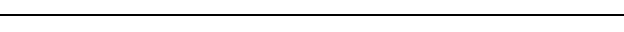

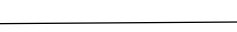
Nº	STRUCTURE	DESCRIPTION	QTY	ZONE*
1		Aluminum bottom frame 1 9/16" H X 1 3/8" D X 152 3/8" L	3	A
2		Aluminum bottom frame 1 9/16" H X 1 3/8" D X 152 3/8" L	1	A
4		Aluminum column (right & front) 2 3/8" H X 2 3/8" D X 96 3/16" L	1	A
5		Aluminum column (left & front) 2 3/8" H X 2 3/8" D X 96 3/16" L	1	A
6		Aluminum column (right & rear) 2 3/8" H X 2 3/8" D X 80 3/8" L	1	A
7		Aluminum column (left & rear) 2 3/8" H X 2 3/8" D X 80 3/8" L	1	A
8		Door frame (top) 2 1/2" H X 1 9/16" D X 58 7/16" L	1	A
9		Door frame (bottom) 2 1/2" H X 1 9/16" D X 58 7/16" L	1	A
10		Door frame (left) 2 1/2" H X 1 9/16" D X 79 1/8" L	1	A
11		Door frame (right) 2 1/2" H X 1 9/16" D X 79 1/8" L	1	A
12		Aluminum column 2 3/8" H X 1 5/16" D X 96 3/16" L	2	A
13		Aluminum column 2 3/8" H X 1 5/16" D X 88 1/4" L	2	A
14		Aluminum column 2 3/8" H X 1 5/16" D X 79 5/8" L	1	A
15		Aluminum roof beam 4 3/4" H X 1 9/16" D X 172 7/8" L	5	B
16		Aluminum roof outer frame (Left & Right) 7 1/8" H X 1 9/16" D X 174 5/16" L	2	B
17		Aluminum roof outer frame (Front) 7 1/8" H X 1 9/16" D X 176" L	1	B
18		Aluminum roof outer frame (Back) 5 1/2" H X 1 9/16" D X 176" L	1	B
19		Aluminum U profile 1 1/2" H X 1 3/16" D X 21 11/16" L	2	B
20		Aluminum U profile 1 1/2" H X 1 3/16" D X 25 3/4" L	8	B
21		Aluminum U profile 1 1/2" H X 1 3/16" D X 16 1/2" L	2	B
22		Gutter for roof 5 1/4" H X 3 9/16" D X 176 13/16" L	1	B
23		Window kit 37 13/16" H X 23 5/8" D	2	A
24		Vent 19 11/16" H X 8 1/8" D	2	A
25		Door kit 78 3/4" H X 59 1/16" D	1	C
26		PVC Roof panel 43 5/16" H X 1" D X 174 7/16" L	5	C
27		WPC Wall board 6 5/16" H X 1 1/8" D X 73 7/8" L	74	A
28		WPC Wall board 6 5/16" H X 1 1/8" D X 73 7/8" L	2	A















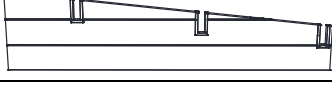
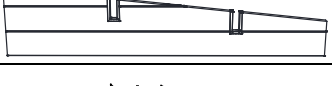









N°	STRUCTURE	DESCRIPTION	QTY	ZONE*
29		WPC Wall board 6 5/16" H X 1 1/8" D X 11 9/16" L	24	A
30		WPC Wall board 6 5/16" H X 1 1/8" D X 57 7/8" L	3	A
31		WPC Wall board 6 5/16" H X 1 1/8" D X 44 3/8" L	20	A
32		WPC Wall board 6 5/16" H X 1 1/8" D X 28 1/4" L	4	A
33		Composite Wall Panel 6 5/16" H X 1 1/8" D X 73 7/8" L	2	A
34		Composite Wall Panel 6 5/16" H X 1 1/8" D X 73 15/16" L	2	A
A		Screw and plastic dowel #8 x 80mm	16	A
B		Screw #4 x 20mm	300	A
C		L bracket for column 2 9/16" H X 0.79" D X 2 9/16" L	18	A
D		Door connector	4	A
E		Door frame mounting	8	A
F		Hexagon key	1	A
G		L bracket for beam 1 9/16" H X 1 9/16" D X 1 9/16" L	34	B
H		L bracket for roof outer beam	4	B
I		Beam clamp plug	10	B
J		Screw for PVC roof #5 x 75mm	100	C
K		Rain cap for roof screw	100	C
L		Screw bit	1	C
M		Gutter cover	1	C
N		Gutter cover	1	C
O		Roof plug	36	C
P		Door lock	1	C
Q		Connector rail	1	B
R		Connector rail	2	B
S		Window Lock	2	
T		Screw #6 x 30mm	16	
V		2 15/16" PVC Gutter downspout L = 78 3/4"	1	

* Stickers on the products are for Zone information.

*Pieces are separated and identified in 3 parts for an easy installation.

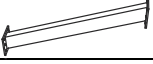
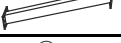
A : first installed part; B : second installed part; C : last installed part.

N°	STRUCTURE	DESCRIPTION	QTY	ZONE*
1		Cadre inférieur en aluminium 1 9/16" H X 1 3/8" P X 152 3/8" L	3	A
2		Cadre inférieur en aluminium 1 9/16" H X 1 3/8" P X 152 3/8" L	1	A
4		Colonne en aluminium 2 3/8" H X 2 3/8" P X 96 3/16" L	1	A
5		Colonne en aluminium 2 3/8" H X 2 3/8" P X 96 3/16" L	1	A
6		Colonne en aluminium 2 3/8" H X 2 3/8" P X 80 3/8" L	1	A
7		Colonne en aluminium 2 3/8" H X 2 3/8" P X 80 3/8" L	1	A
8		Cadre de porte haut 2 1/2" H X 1 9/16" P X 58 7/16" L	1	A
9		Cadre de porte bas 2 1/2" H X 1 9/16" P X 58 7/16" L	1	A
10		Cadre de porte gauche 2 1/2" H X 1 9/16" P X 79 1/8" L	1	A
11		Cadre de porte droit 2 1/2" H X 1 9/16" P X 79 1/8" L	1	A
12		Cadre en aluminium 2 3/8" H X 1 5/16" P X 96 3/16" L	2	A
13		Cadre en aluminium 2 3/8" H X 1 5/16" P X 88 1/4" L	2	A
14		Cadre en aluminium 2 3/8" H X 1 5/16" P X 79 5/8" L	1	A
15		Cadre de toit en aluminium 4 3/4" H X 1 9/16" P X 172 7/8" L	5	B
16		Cadre extérieur de toit en aluminium (droite et gauche) 7 1/16" H X 1 9/16" P X 174 5/16" L	2	B
17		Cadre extérieur de toit en aluminium (frontal) 7 1/16" H X 1 9/16" P X 176" L	1	B
18		Cadre extérieur de toit en aluminium (arrière) 5 1/2" H X 1 9/16" P X 176" L	1	B
19		Profilé U en aluminium 1 7/16" H X 1 3/16" P X 21 11/16" L	2	B
20		Profilé U en aluminium 1 7/16" H X 1 3/16" P X 25 12/16" L	8	B
21		Profilé U en aluminium 1 7/16" H X 1 3/16" P X 16 8/16" L	2	B
22		Gouttière de toit 5 1/4" H X 3 9/16" P X 176 13/16" L	1	B
23		Fenêtre 37 13/16" H X 23 5/8" P	2	A
24		Grille de ventilation 19 11/16" H X 8 1/16" P	2	A
25		Porte 78 3/4" H X 59 1/16" P	1	C
26		Panneau de toit en PVC 43 5/16" H X 31/32" P X 174 7/16" L	5	C
27		Planche murale en composite 6 5/16" H X 1 10/16" P X 73 7/8" L	74	A
28		Planche mural en composite 6 5/16" H X 1 10/16" P X 73 7/8" L	2	A

N°	STRUCTURE	DESCRIPTION	QTY	ZONE*
29		Planche murale en composite 6 5/16" H X 1 5/8" D X 11 9/16" L	24	A
30		Planche murale en composite 6 5/16" H X 1 5/8" D X 57 7/8" L	3	A
31		Planche murale en composite 6 5/16" H X 1 5/8" D X 44 3/8" L	20	A
32		Planche murale en composite 6 5/16" H X 1 5/8" D X 28 1/4" L	4	A
33		Panneau mural en composite 6 5/16" H X 1 5/8" D X 73 7/8" L	2	A
34		Panneau mural en composite 6 5/16" H X 1 5/8" P X 73 7/8" L	2	A
A		Vis et cheville en plastique #8 x 80mm	16	A
B		Vis #4 x 20mm	300	A
C		Connecteur de colonne en L 2 9/16" H X 13/16" P X 2 9/16" L	18	A
D		Connecteur de porte	4	A
E		Cadre de porte	8	A
F		Clé Allen	1	A
G		Connecteur de poutre en L 1 9/16" H X 1 9/16" P X 1 9/16" L	34	B
H		Connecteur de poutre extérieur de toit en L	4	B
I		Serre-poutre	10	B
J		Vis pour le toit #5 x 75mm	100	C
K		Protection anti-pluie pour vis de toit	100	C
L		Embout pour visseuse	1	C
M		Embout de gouttière	1	C
N		Embout de gouttière	1	C
O		Bouchon de toit	36	C
P		Poignée de porte	1	C
Q		Rail de connexion	1	B
R		Rail de connexion	2	B
S		Window Lock	2	
T		Vis #6 x 30mm	16	
V		2 15/16" Gouttière PVC L = 78 3/4"	1	

* Les autocollants sur les produits sont destinés aux informations de zone.

*Pieces are separated and identified in 3 parts for an easy installation.

A : first installed part ; B : second installed part ; C : last installed part.



EN BACK VIEW
FR VUE ARRIÈRE



FRONT VIEW
VUE FRONTALE

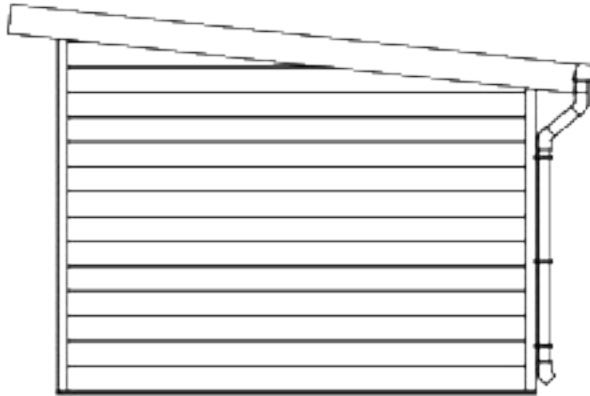

EN SIDE VIEW
FR VUE LATÉRALE

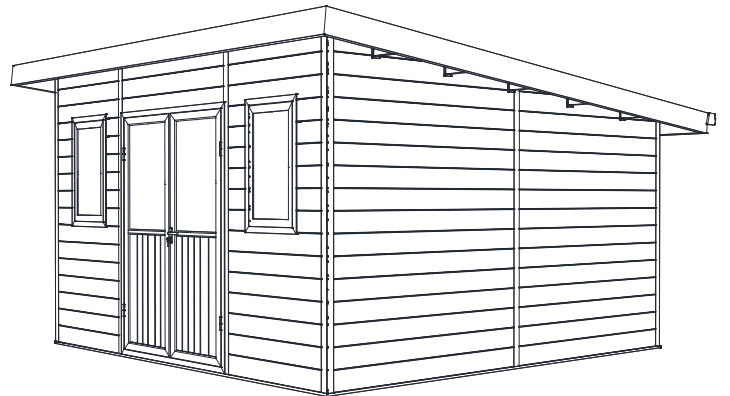

AXONOMETRIC VIEW
PERSPECTIVE

TOOLS REQUIRED FOR INSTALLATION
OUTILS NÉCESSAIRES POUR L'INSTALLATION



GROUND REQUIREMENTS PRÉ-REQUIS AU SOL

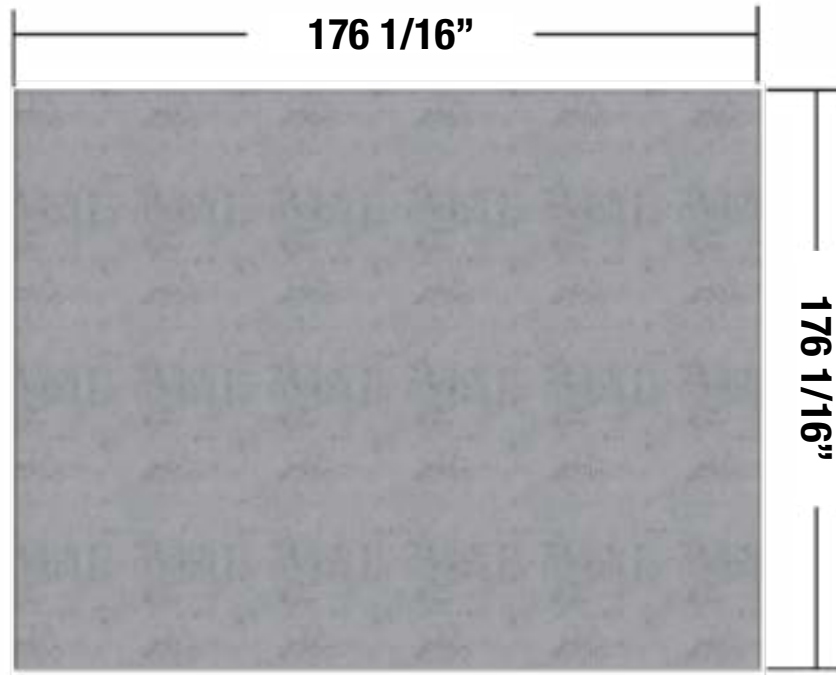

EN Composite shed should be installed on the hard ground like concrete foundation, the surface of ground should be flat and the size should follow the dimension of drawing.

FR Le cabanon en composite doit être installé sur un sol dur comme une fondation en béton, la surface du sol doit être plate et la taille doit suivre la dimension du dessin.

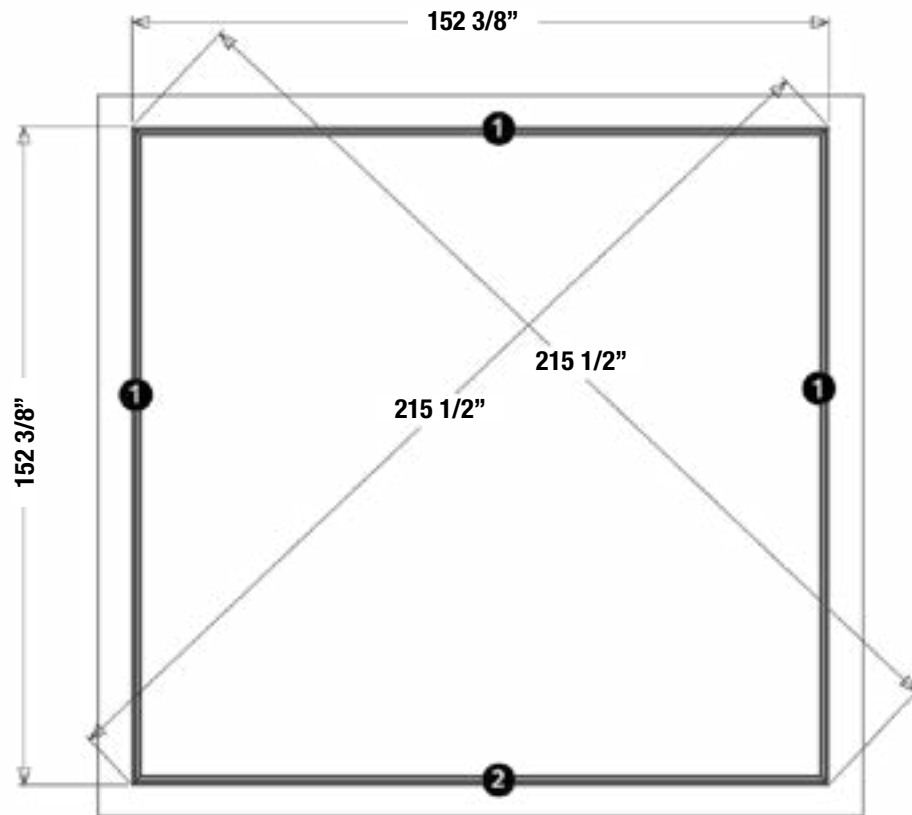

EN Frame out the installation area by using chalk. Check the leveling before starting the installation process – the foundation is key to guarantee the safety and the durability of your composite shed(s).

FR Définissez la zone d’installation à la craie. Une bonne fondation est très importante pour garantir la sécurité et la solidité de votre cabanon en composite, vérifiez que celle-ci est bien plane.

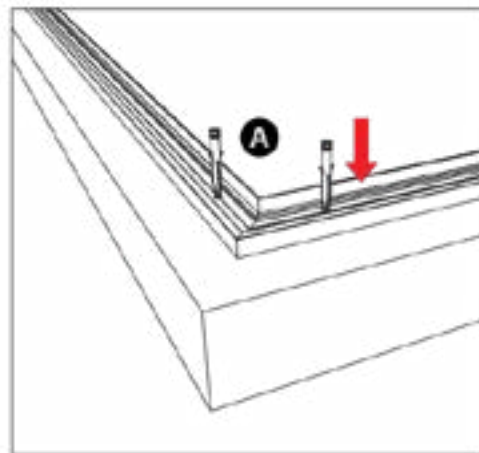
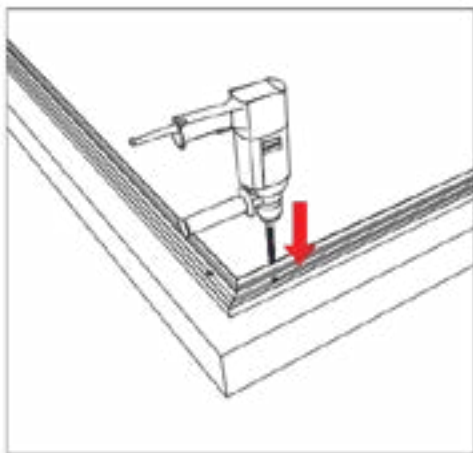

EN Place the dowels in the holes and screw them into the ground as much as possible.

FR Placez les chevilles dans les trous et vissez dans le sol autant que possible.

COLUMN POSITION VIEW POSITION DES COLONNES

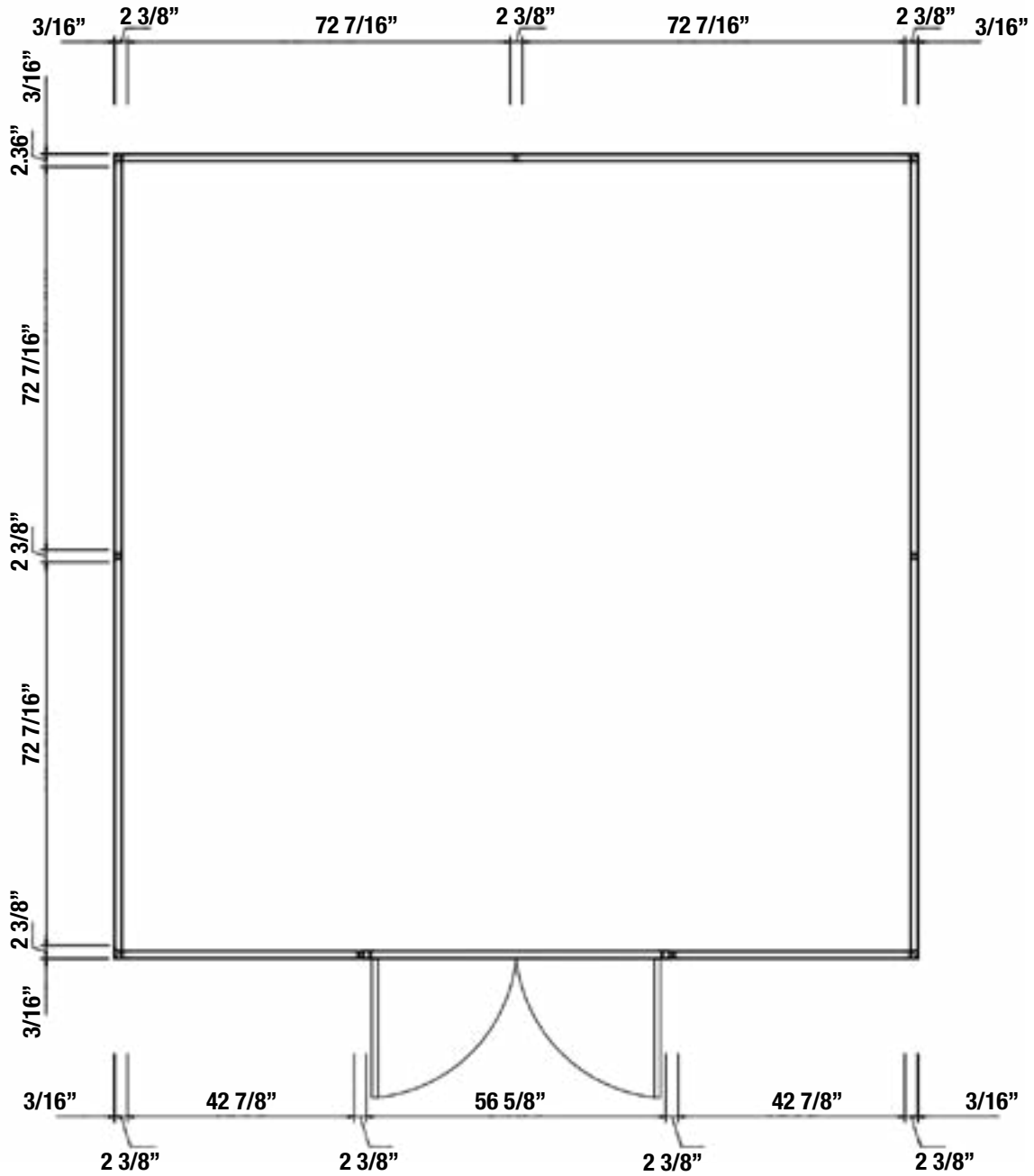

EN Respect the above spacing when installing the columns.

FR Veuillez respecter l'espace ci-dessus pour l'installation des colonnes.

EN Left rear column

FR Colonne arrière gauche

EN Left front column

FR Colonne avant gauche

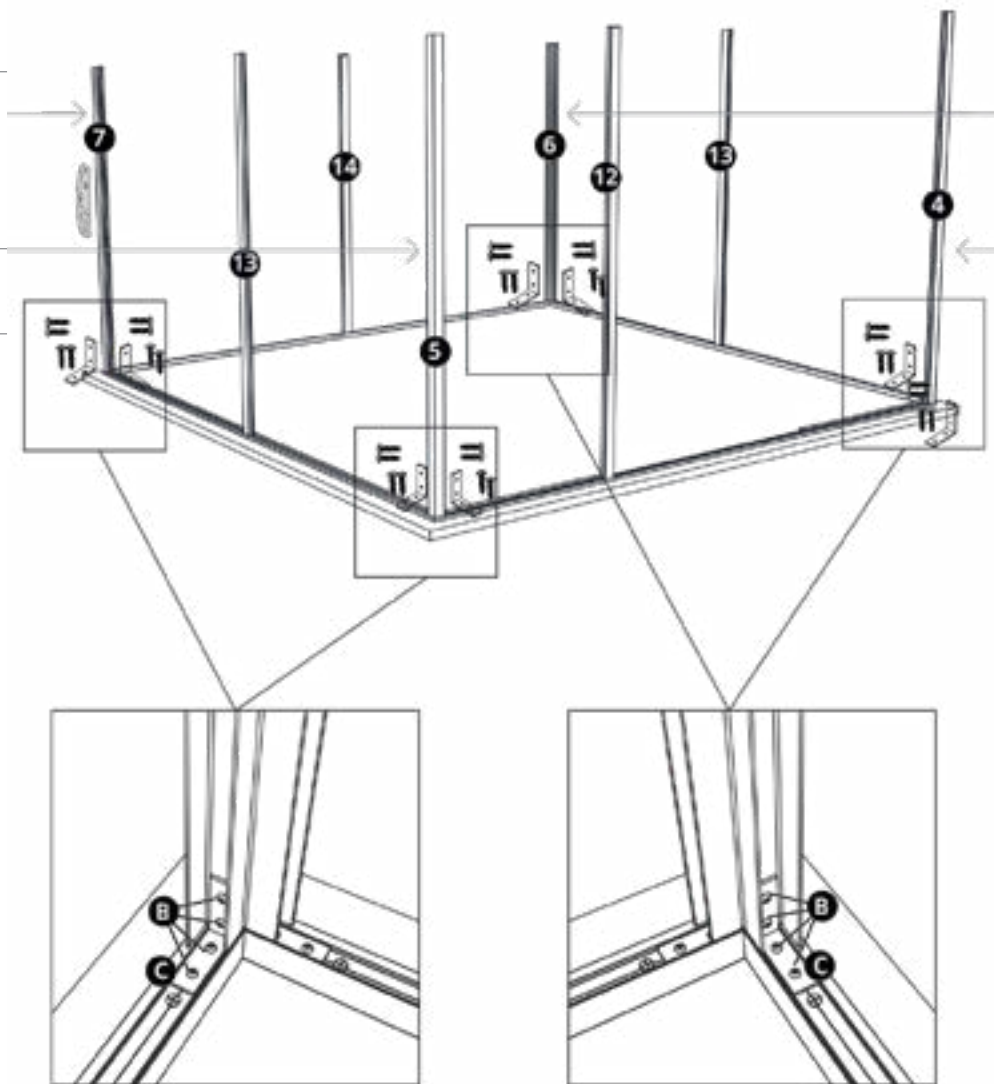

EN Right rear column

FR Colonne arrière droite

EN Right front column

FR Colonne avant droite

EN Install the columns to the right position and fix them with the L brackets and screws. **Make sure that they are placed vertically.**

FR Installez les colonnes dans le bon sens et fixez-les en vissant les connecteurs de colonnes en L et les vis. **Assurez-vous de leur verticalité.**

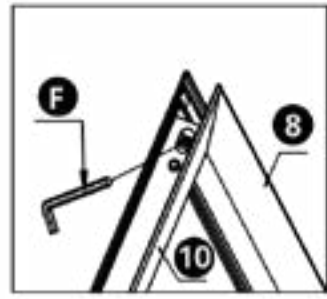
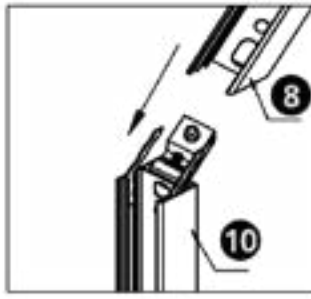
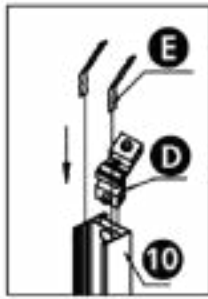

EN Fix the door frame with connection acc. and fasten with hexagon key. Follow the instructions on the adhesive for the top and bottom of the door frame.

FR Assemblez les cadres de porte grâce aux connecteurs de porte avec la clé Allen. Suivez les indications du collant pour le haut et le bas du cadre de porte.

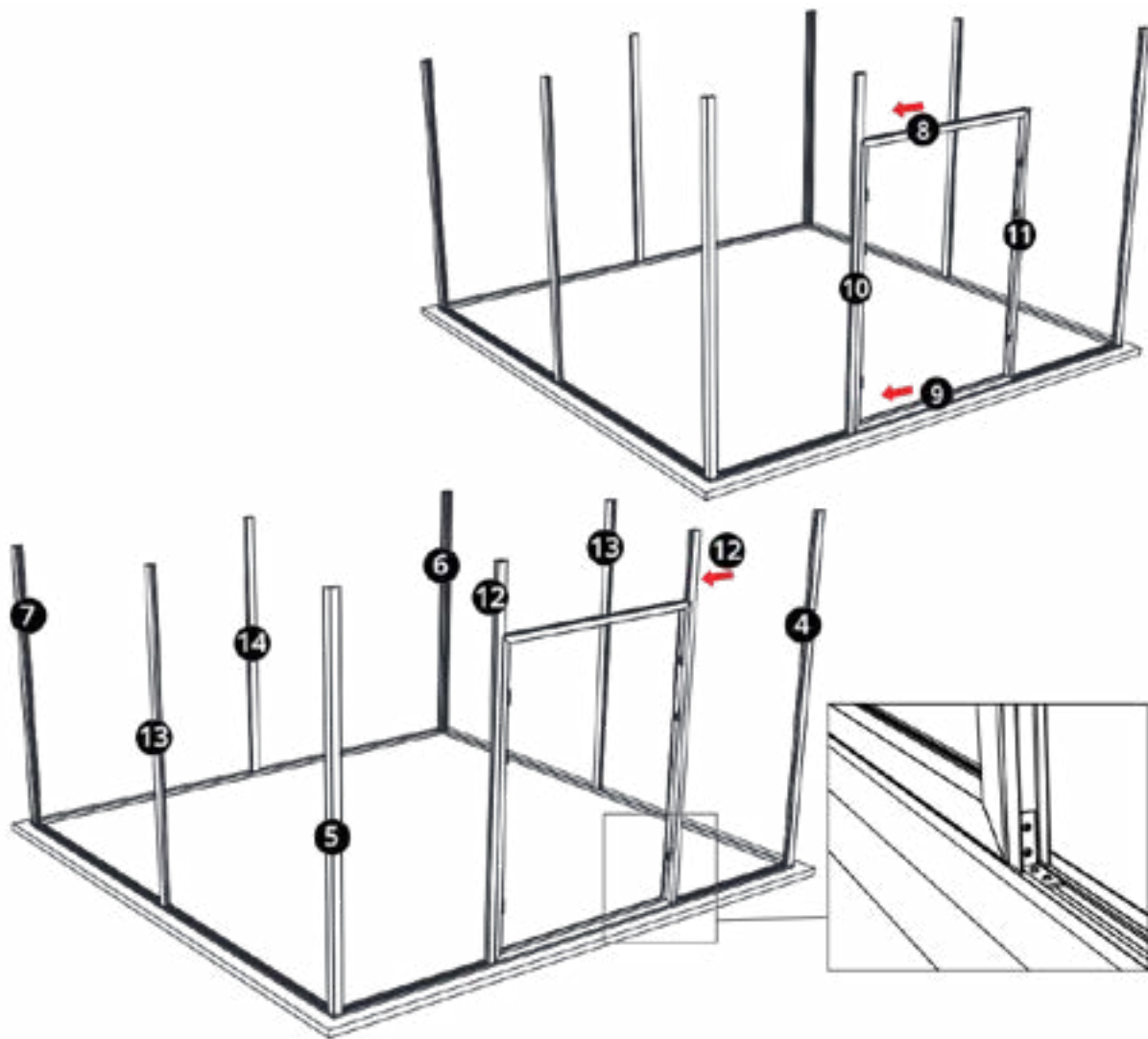

EN Put the door frame on the aluminum bottom frame, fixing them by screwing the connectors of the L-shaped columns.

FR Insérez le cadre de porte sur le cadre inférieur en aluminium et fixez l'autre colonne avec un connecteur de colonne en L.

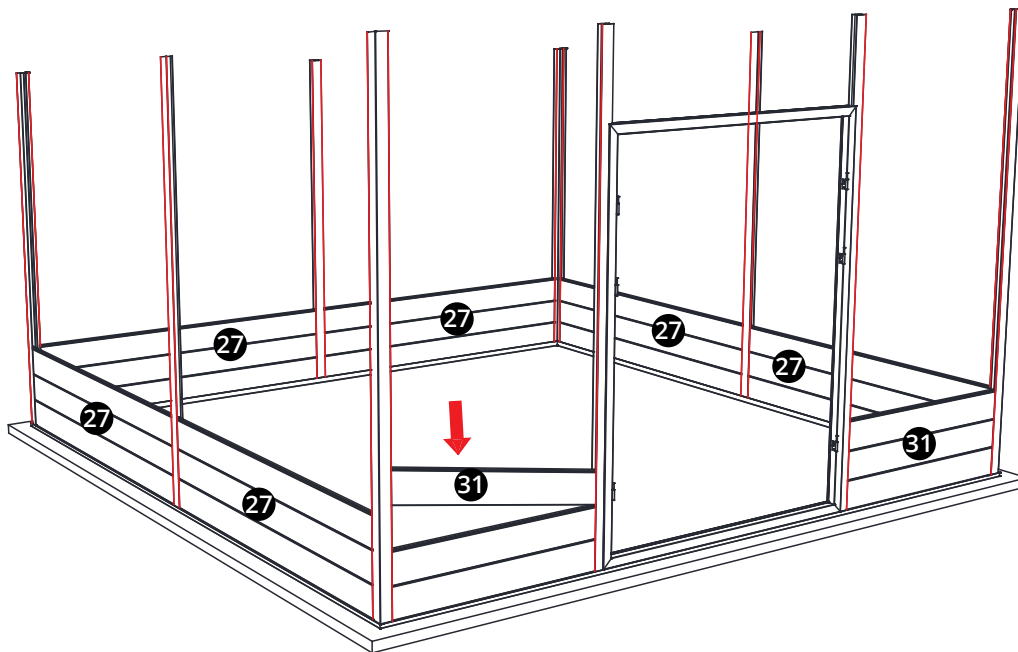

EN Install the wall panels one by one. We suggest that you install them equally to each unit so that the whole frame becomes stable. Use a sealant gun to apply a bead of sealant inside the column, following the red line.

FR Installez la première ligne de planches murales sur chaque pan de mur et procédez de la même façon pour les autres. Utiliser un fusil à scellant pour ajouter un jet de scellant à l'intérieur de la colonne, en suivant la ligne rouge.

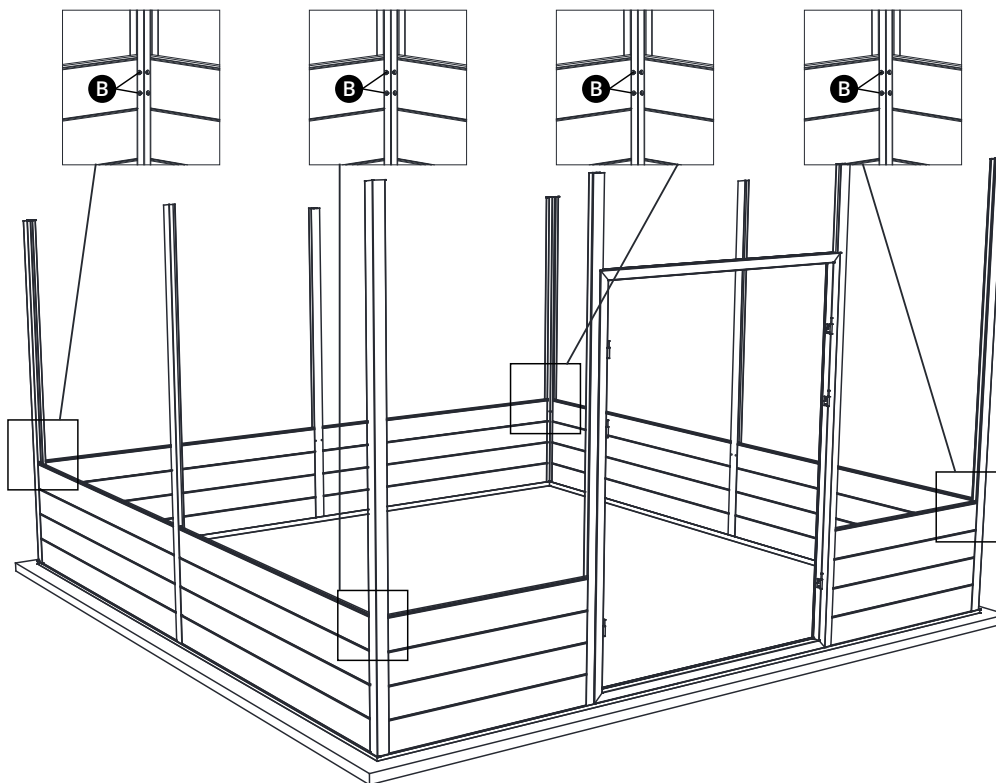

EN Screw through each column to the wall panel every 4 boards using 2 screws – making sure the columns are vertical.

FR Vissez chaque colonne à toutes les 4 planches du panneau mural à l'aide de 2 vis – en vous assurant que les colonnes demeurent bien verticales.

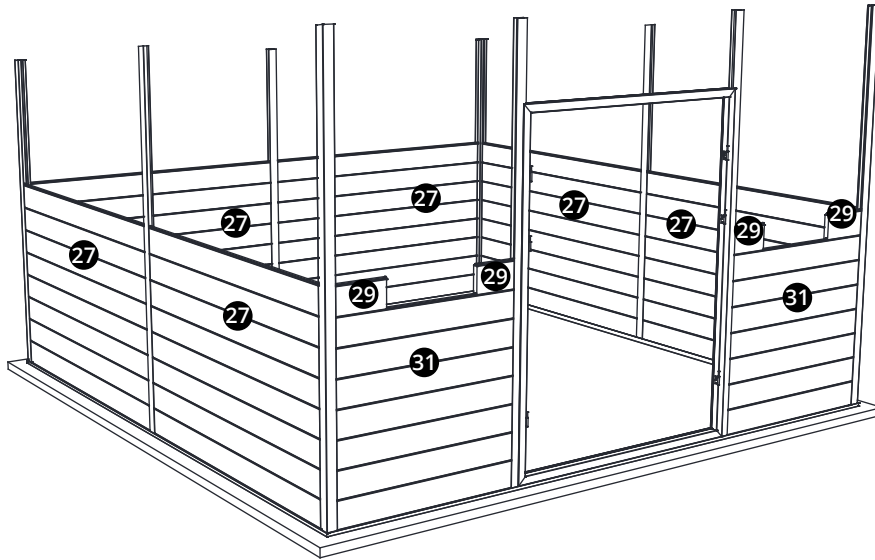

EN Install the wall panels according to the picture shown above.

FR Installez les planche murales comme illustré ci-dessus.

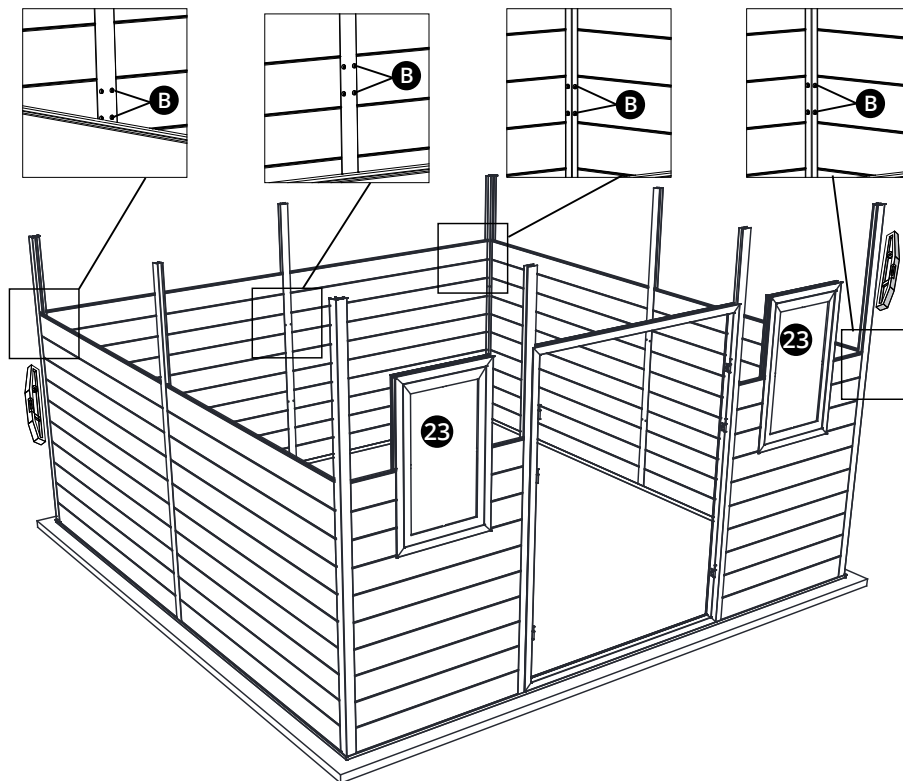

EN Screw every 4 boards and make sure the columns are vertical before screwing with 2 screws. Then, install the window kits. **These are inward opening windows, make sure to not mistake the left from the right kits when installing them.**

FR N'oubliez pas de visser aux colonnes toutes les 4 planches à l'aide de 2 vis. Installez la fenêtre. **Les fenêtres s'ouvrent de l'intérieur, ne pas se tromper de sens lors de l'installation.**

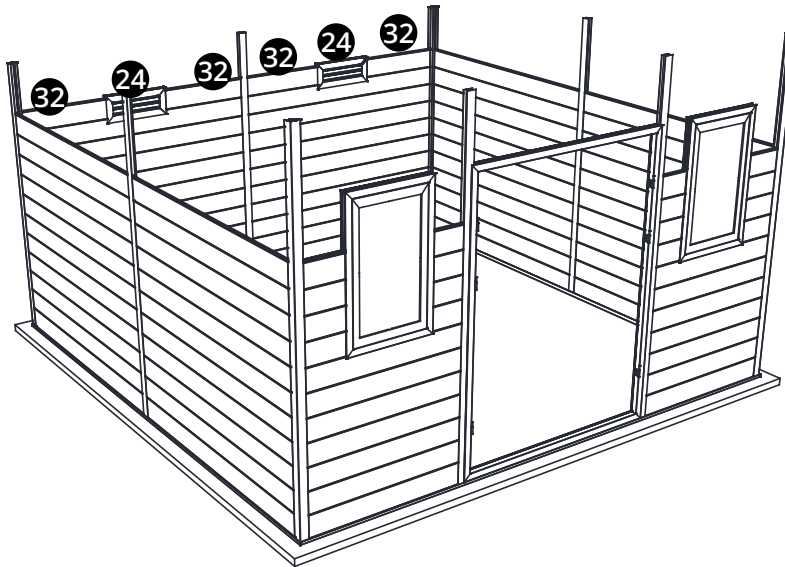

EN Put the vent kits upon the 10th board of the wall panel back side - put the short wall panel as per in the picture.

FR Mettez les grilles de ventilation au dessus de la 10^{ème} planche à l'arrière du cabanon. Entourez les grilles de ventilation de planches murales plus courtes comme présenté sur l'illustration.

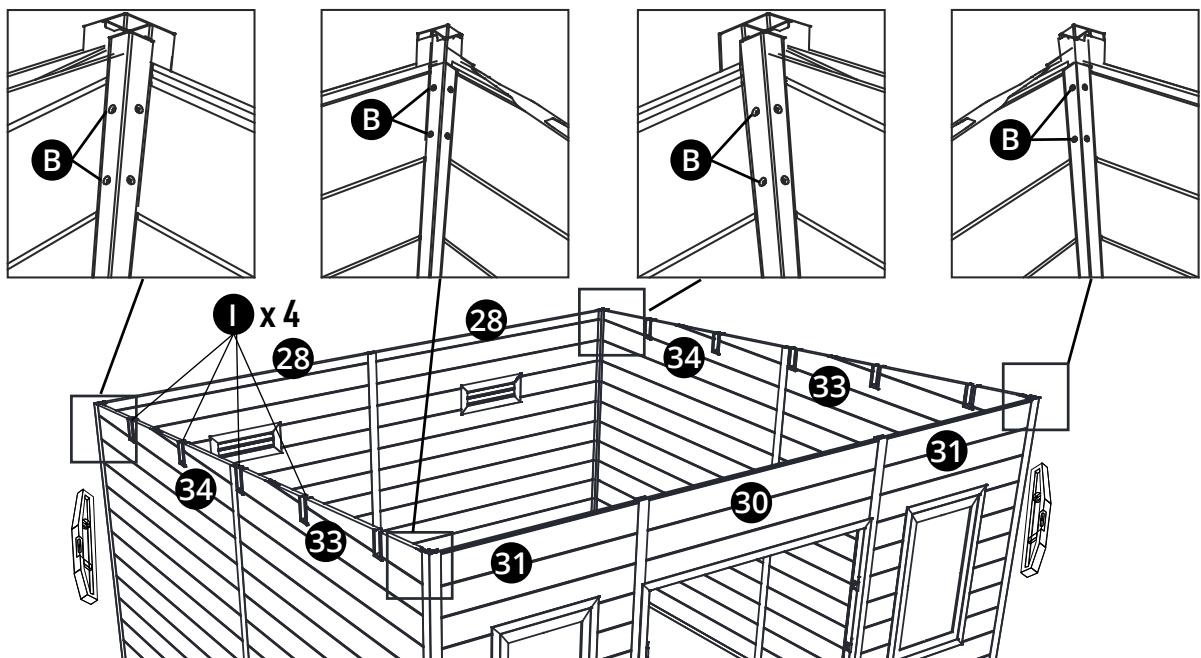

EN After the wall panels are installed in place, fix it with screws between the top wall panel and the column using 2 screws. **(Note: keep the column vertical)** Slide the beam clip into the board slot.

FR Finalisez la pose des planches murales en positionnant les panneaux triangulaires et en les vissant en haut des colonnes à l'aide de 2 vis. **(NOTE : gardez les colonnes verticales)** Placez les serre-poutres dans les encoches.

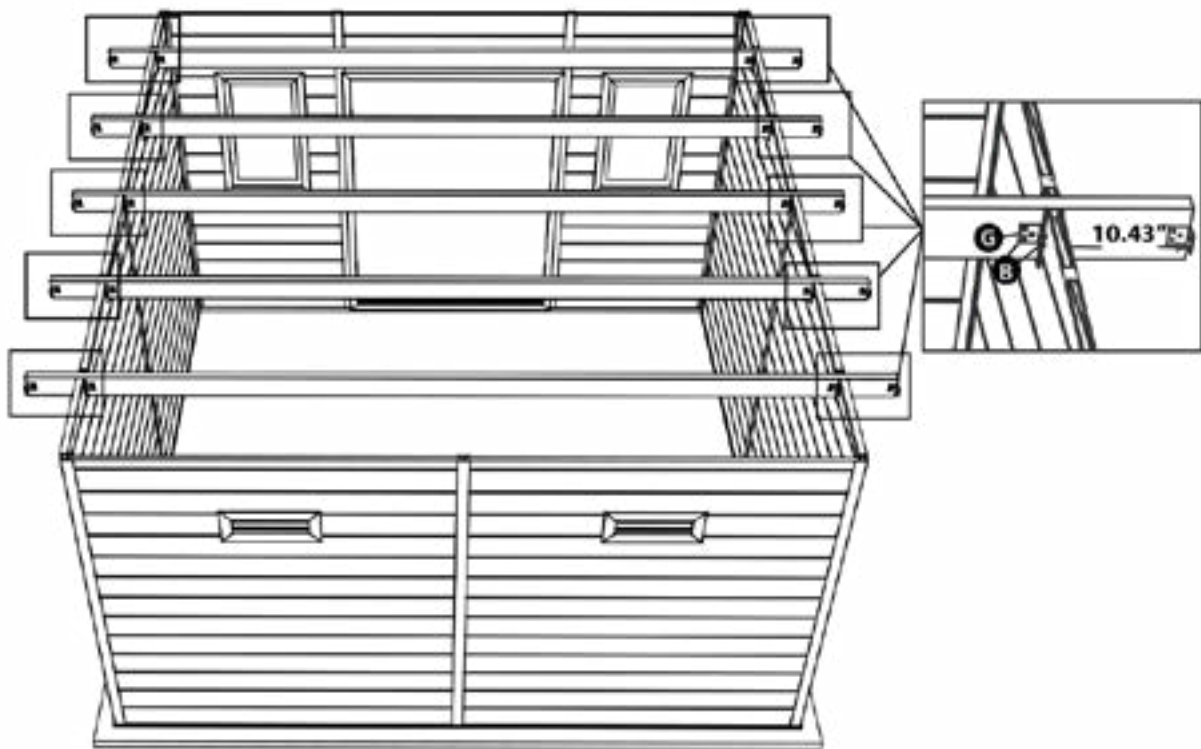
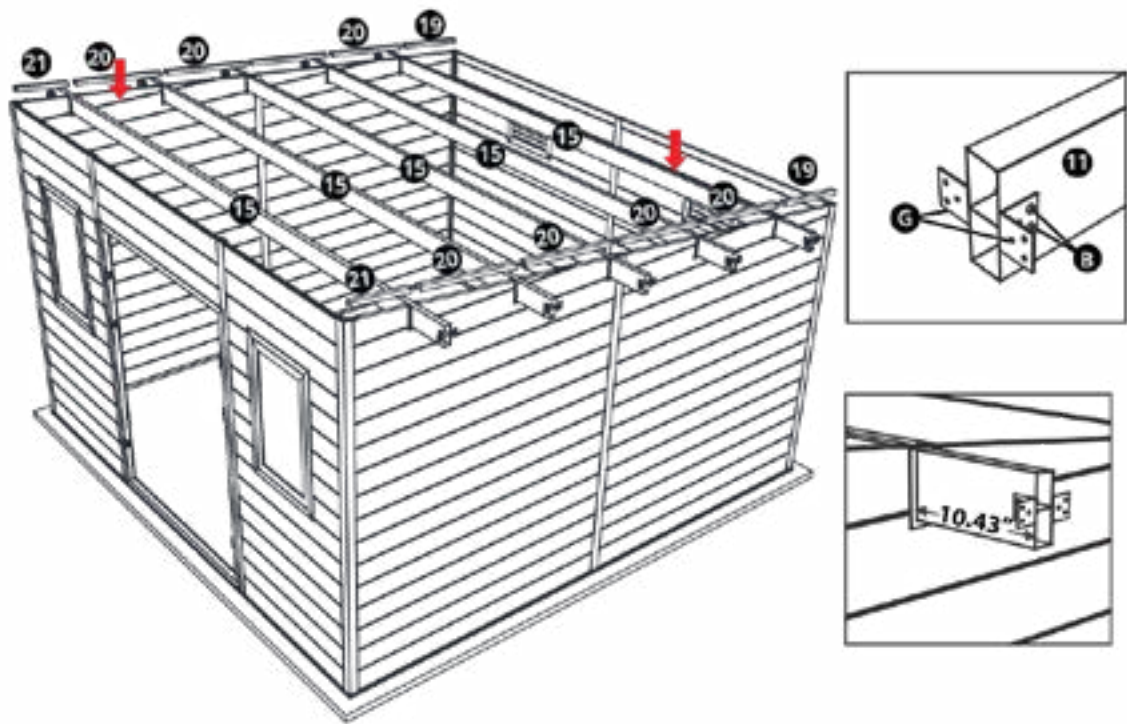

EN Fix the L brackets to the beams, put all beams into plugs, and adjust the position of each beam. **The beam should extend the front wall panel 10.43". Keep the extension as acute as possible.**

FR Fixez les connecteurs de poutre en L aux poutres. Positionnez les poutres dans les serre-poutres et ajustez la position. **Chaque poutre doit dépasser de 10.43", essayez de respecter autant que possible cette position.**

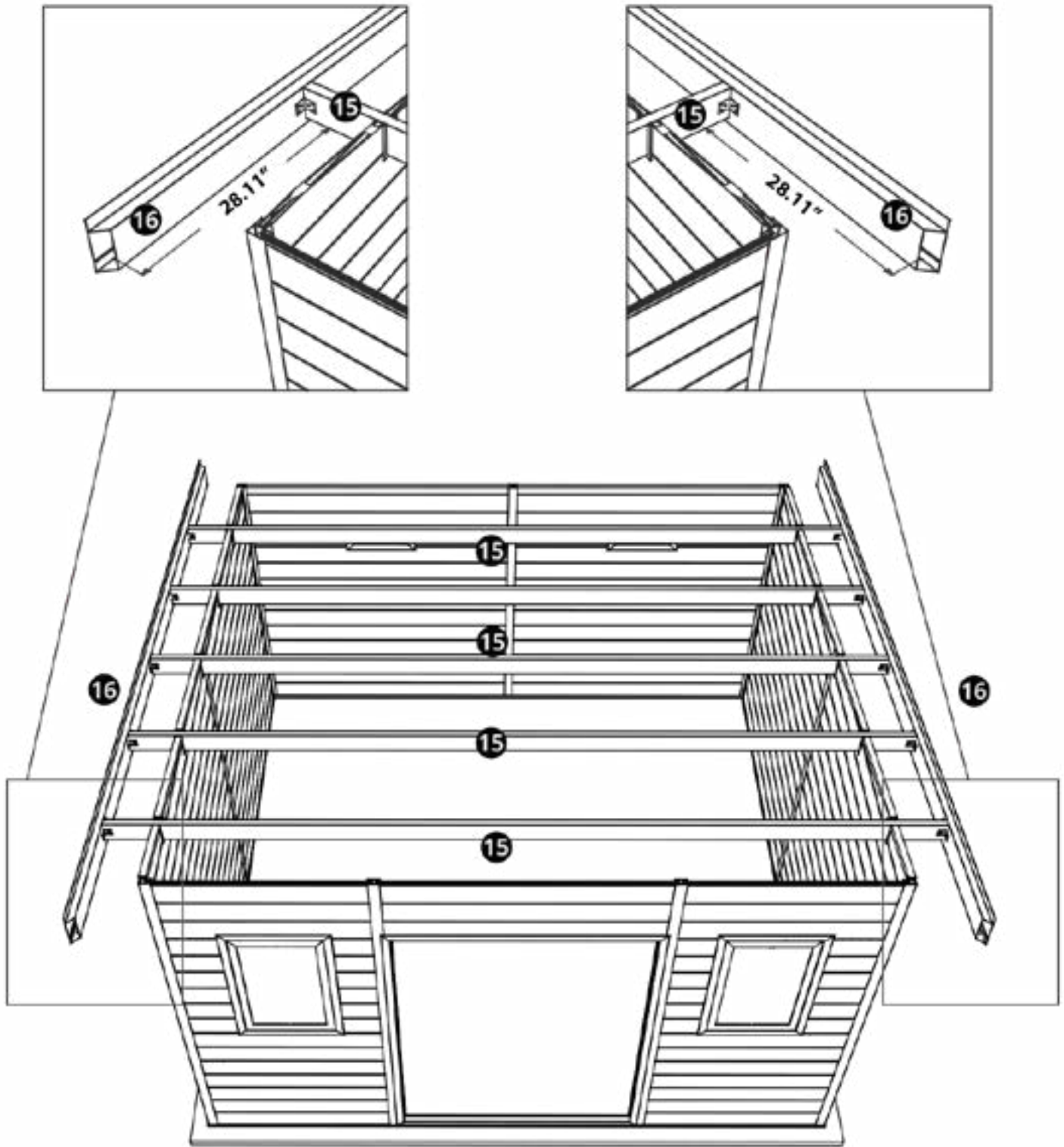

EN Put outer beams of the left and the right and fix with L brackets and screws. **The position of the inner opening of the side beam should be 28.11" away from the beam.** Screw the connecting rail between the last beam and the column.

FR Fixez le cadre extérieur de toit latéral aux poutres grâce aux connecteurs de poutre en L. **Chaque extrémité du cadre doit se trouver à 28.11" de la poutre la plus proche (cf illustration).** Vissez le rail de connexion entre la dernière poutre et la colonne.

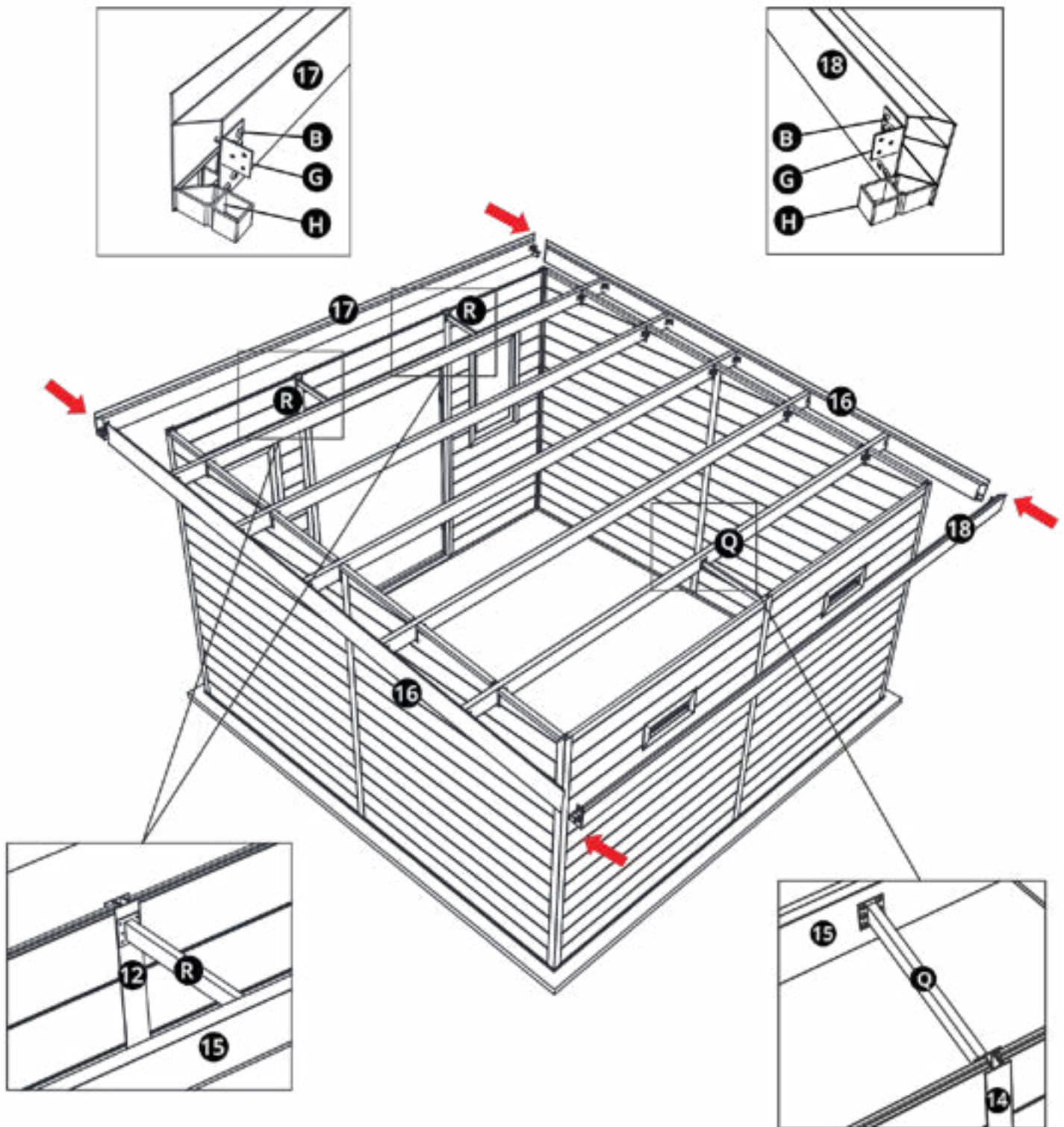

EN Fix the outer frames of the front and the back with the L brackets. Screw the connecting rail between the last beam and the column.

FR Fixez ensuite les cadres extérieurs de toit frontal et arrière grâce aux connecteurs en L. Vissez le rail de connexion entre la dernière poutre et la colonne.

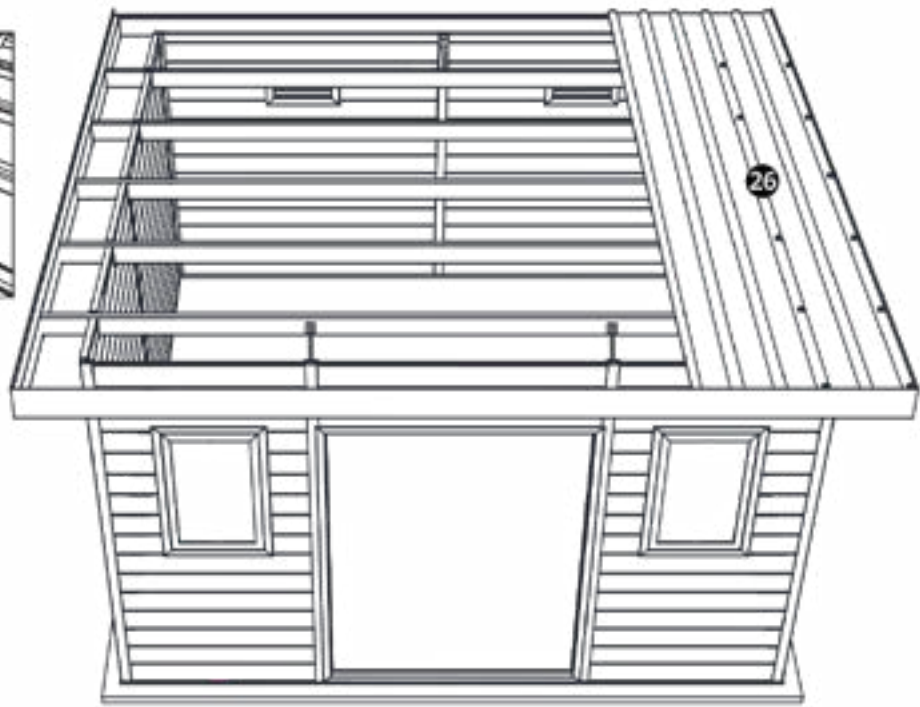
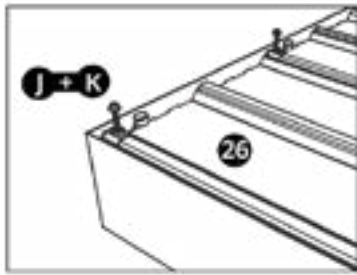

EN Position the first roof panel (gray side out) on the beams. Make sure that the top wall panel is close to the center beam. Screw the panel into each of the beams, with the exception of the exterior side roof beam. Leave a 0.39" space between the roof panel and the front/back frames. **NOTE: Don't fix the last row of screws to the outer beams for the time being.**

FR Positionnez le premier panneau de toit (face grise à l'extérieur) sur les poutres. Assurez-vous que le sommet du panneau mural soit proche de la poutre centrale afin d'y placer une vis. Vissez le panneau sur chacune des poutres, à l'exception du cadre de toit latéral extérieur. Laissez un espace de 0.39" entre le panneau de toit et le cadre de toit extérieur frontal et arrière.

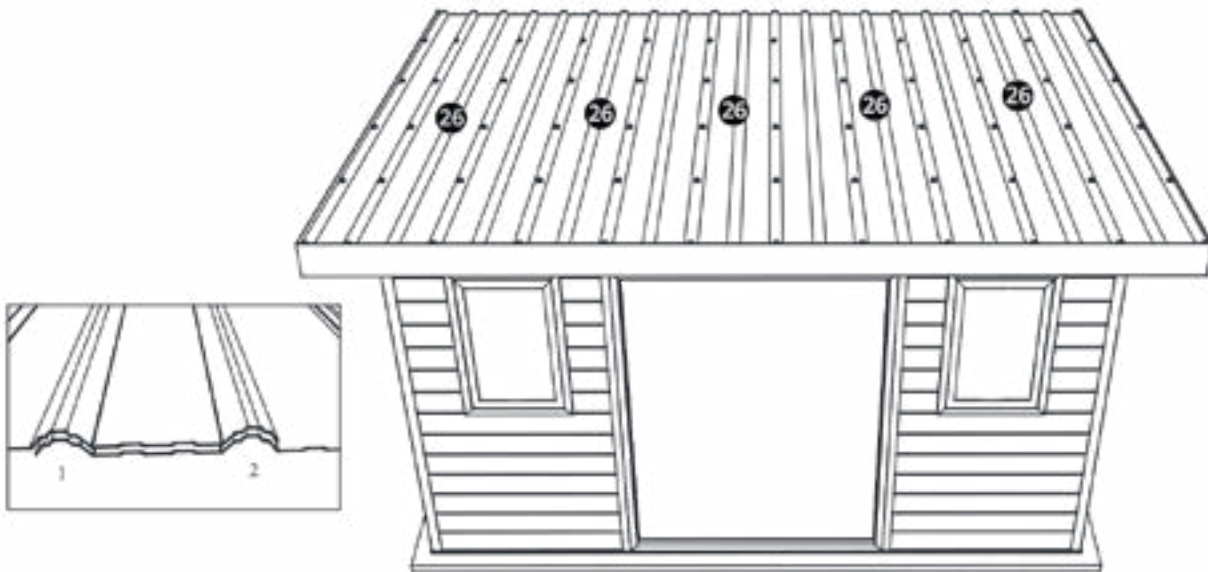

EN Install the other roof panels one by one. The next roof panel must always cover two corrugations of the previous roof panel.

FR Un par un, installez les autres panneaux de toit. Le panneau de toit suivant doit toujours recouvrir deux ondulations du panneau de toit précédent.

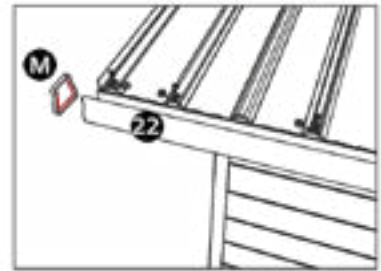

EN Position the gutters and insert the corner into the space between the panel and the exterior roof beam. Place the last row of screws and the exterior side of the roof frame into the panels. Position the gutter end and seal with glue using the caulking gun and the cover.

FR Positionnez les gouttières et insérez le coin dans l'espace entre le panneau et le cadre extérieur de toit. Placez dans les panneaux la dernière rangée de vis sur le cadre de toit latéral extérieur. Positionnez les embouts de gouttière à l'aide de colle.

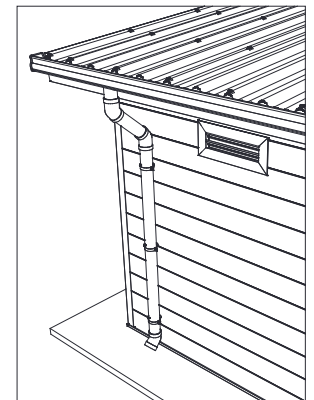
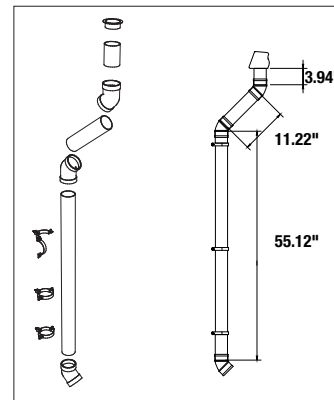
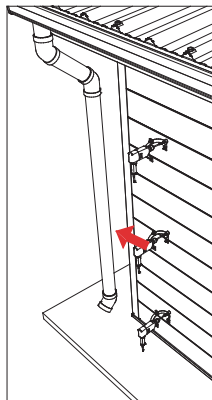
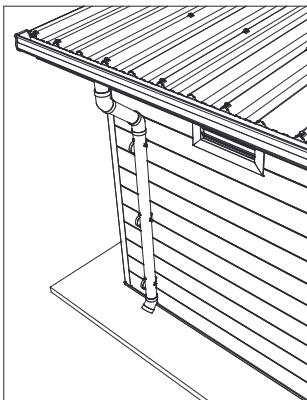
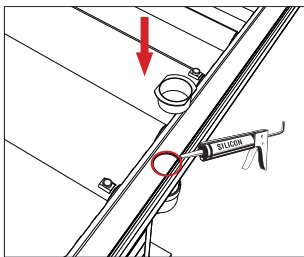
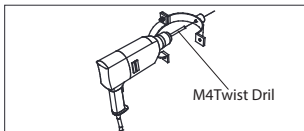
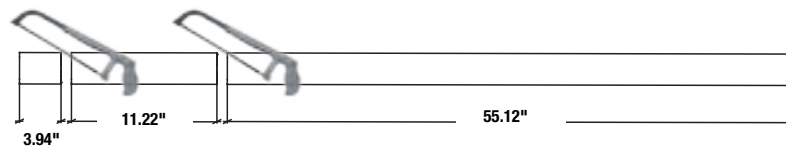

EN Use a saw to cut the drain pipe into 3 pieces according to the length shown above. Before attaching the connection clamps, place the 3 pieces of cut drain pipe and elbows as shown in the picture above, then determine the position of the screws that will be used to anchor the connection clamps to the wall, and drill the holes. Next, remove the drain pipe and elbows, and attach the connection clamps to the wall with screws. Replace the downpipe and elbows and secure them with the connection clamps. Finally, use sealant to seal the gutter outlet.

FR À l'aide d'une scie, coupez le tuyau de descente de gouttières en 3 parties en respectant la longueur indiquée ci-dessus. Avant de fixer les colliers de connexion, placez les 3 parties de la descente coupée et les coudes comme sur la photo ci-dessus, puis établissez la position des vis qui serviront à ancrer les colliers de connexion sur le mur, et percez les trous. Ensuite, retirez la descente et les coudes, puis fixez les colliers de connexions au mur à l'aide de vis. Remettez le tuyau de descente et les coudes en place et fixez-les avec les colliers de connexions. Enfin, utilisez le mastic pour sceller la sortie de la gouttière.

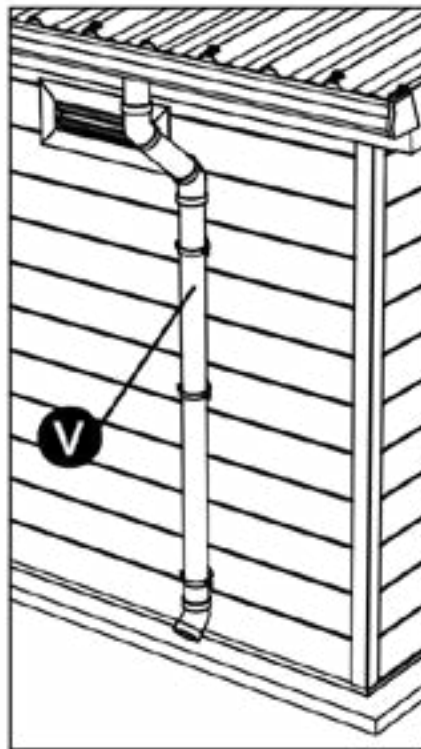
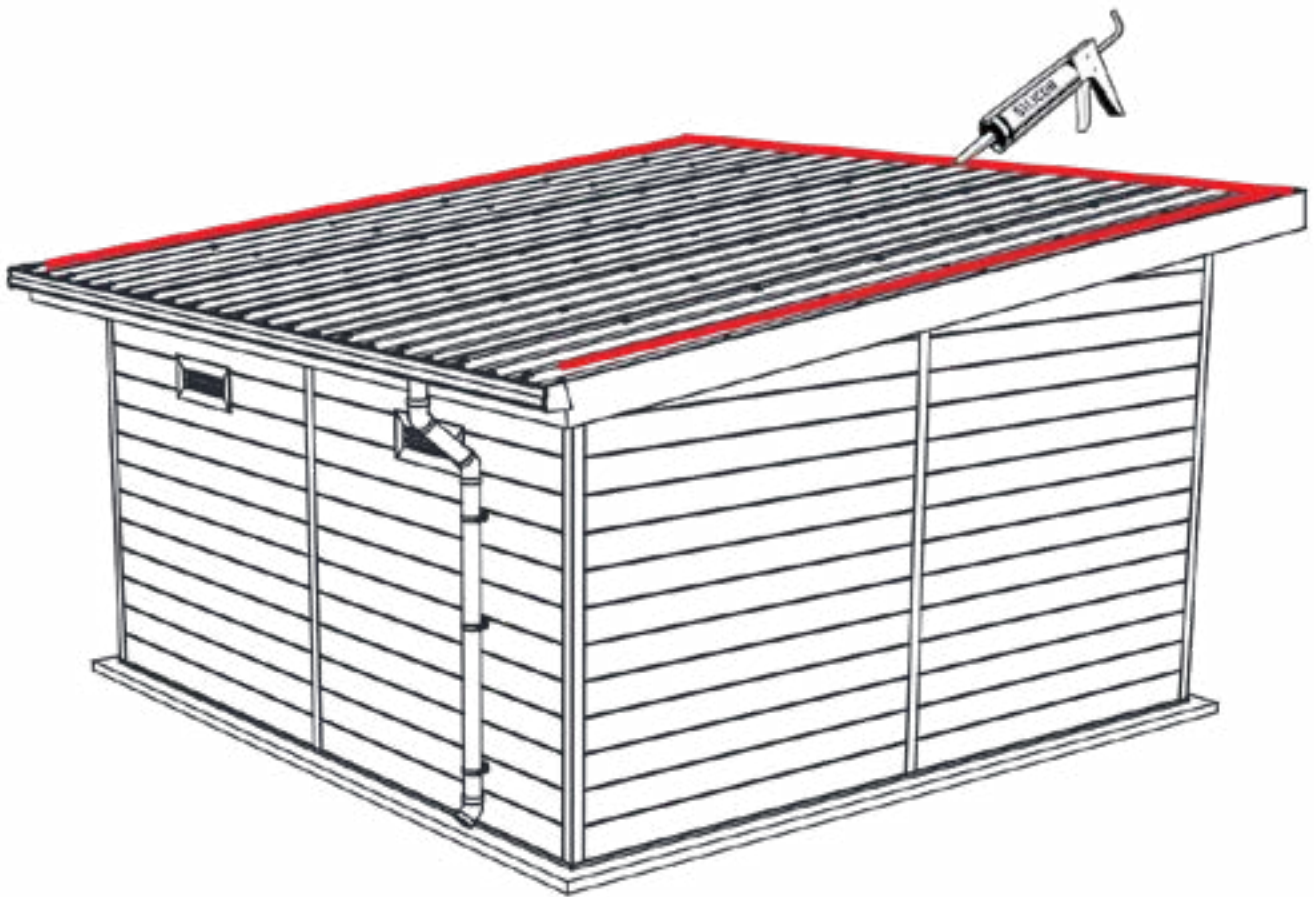

EN Install the gutter downspouts 2.95". Using the caulking gun, create a joint between the roof panel and the front and rear outer roof beam.

FR Installez la descente de gouttière 2.95". A l'aide d'un pistolet, créez un joint entre le panneau de toit et le cadre de toit extérieur frontal et arrière.

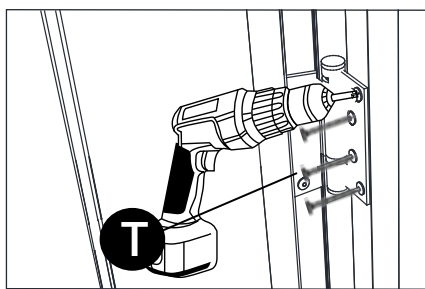
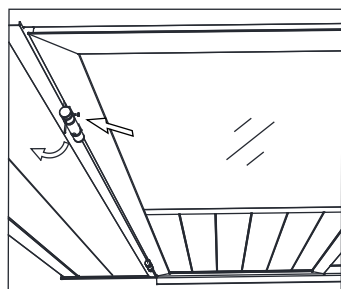
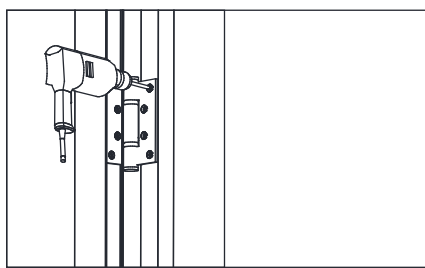
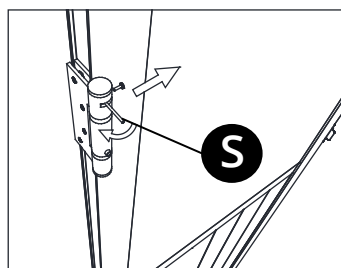
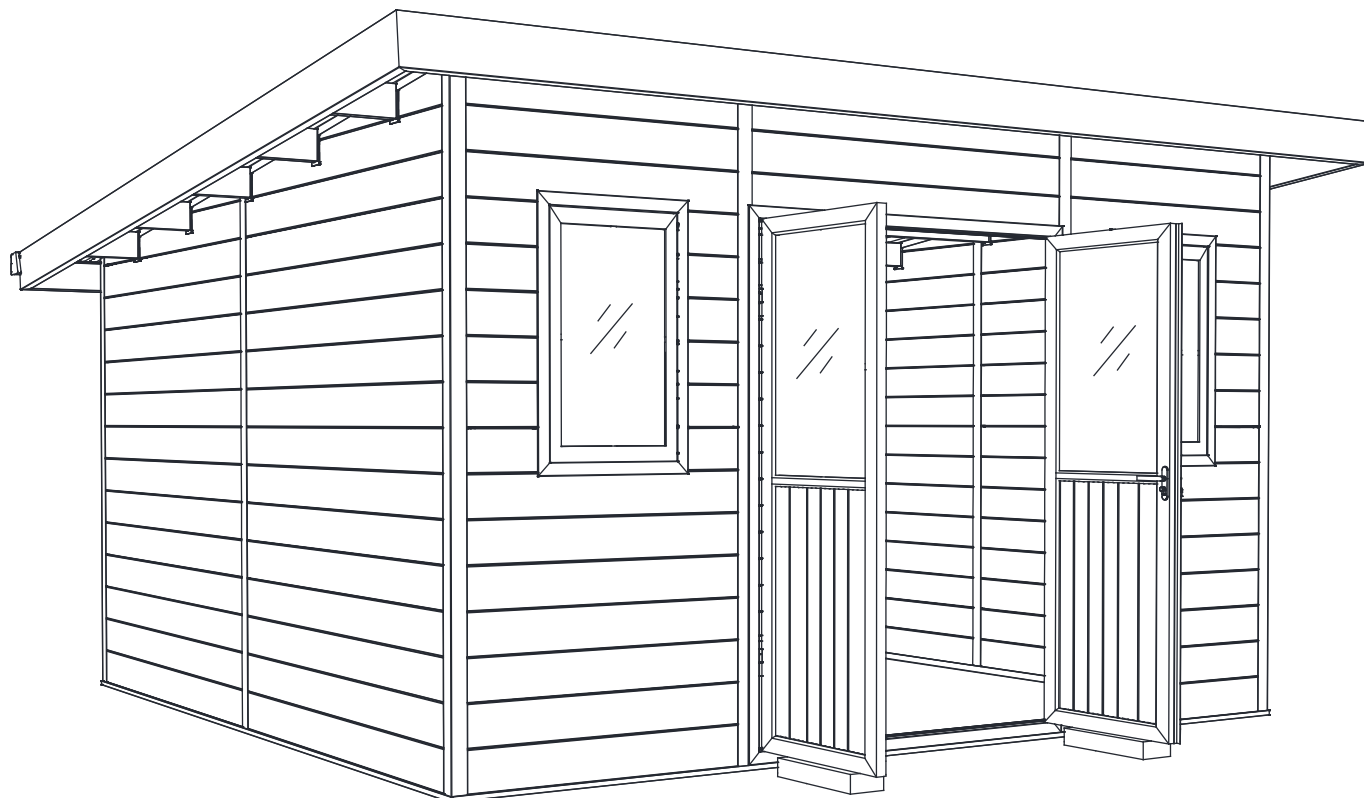

EN Insert the small stick into the regulating hole, then move the stick to left. Take out the locating pin, then put the door to the door frame position, and raise the door to suitable height by putting a brick or other objects underneath the door, and apply a pistol drill to drill holes and fix with screws. Close the door firstly, then insert the small stick into the regulating hole again, and move the stick to left. Adjust suitable strength in accordance with the door's weight, finally, insert the locating pin.

FR Insérez le petit bâton dans le trou de régulation, puis déplacez le bâton vers la gauche. Retirez la goupille de positionnement, puis placez la porte dans la position du cadre de porte et soulevez la porte à la hauteur appropriée en plaçant une brique ou d'autres objets sous la porte, et utilisez une perceuse à pistolet pour percer des trous et fixer avec des vis. Fermez d'abord la porte, puis insérez à nouveau le petit bâton dans le trou de régulation et déplacez le bâton vers la gauche. Ajustez la tension appropriée en fonction du poids de la porte, enfin, insérez la goupille de positionnement.

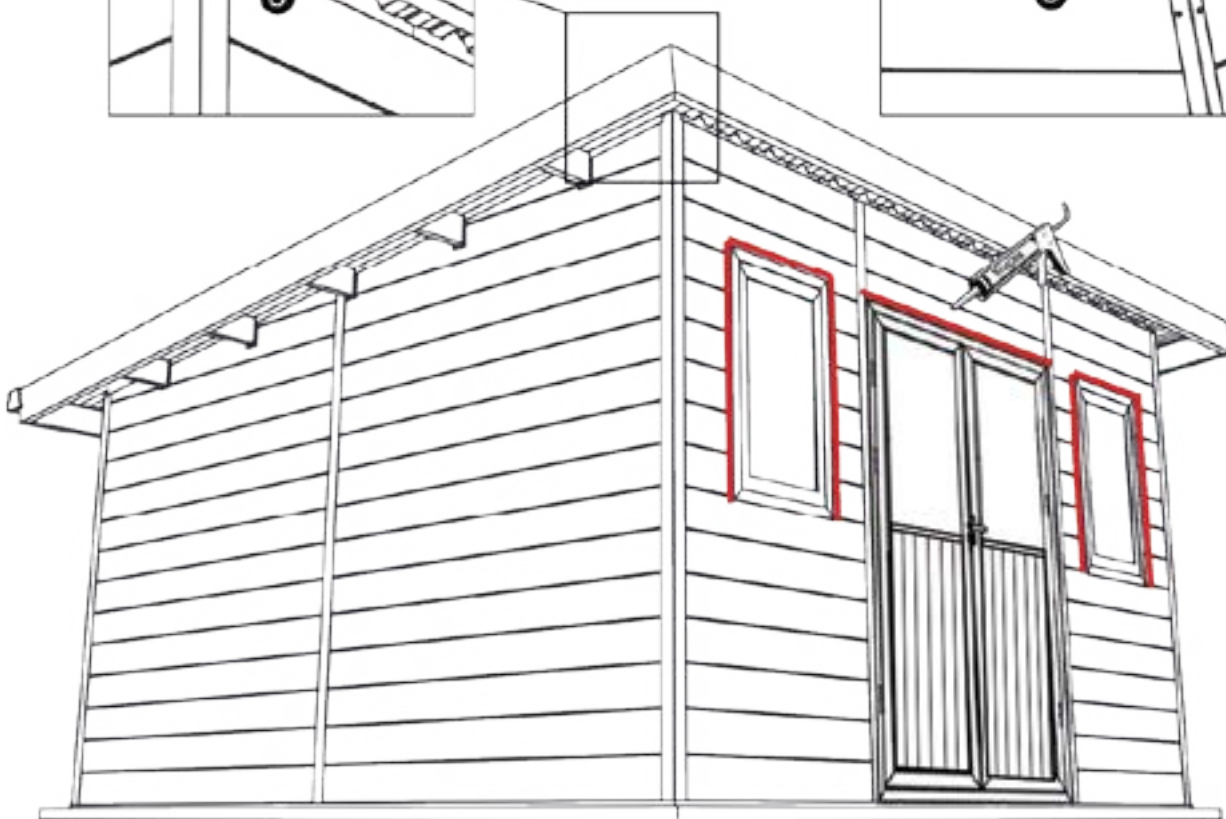
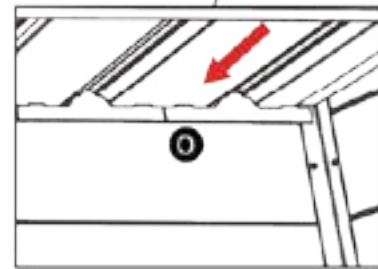
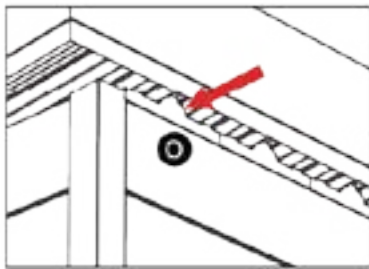
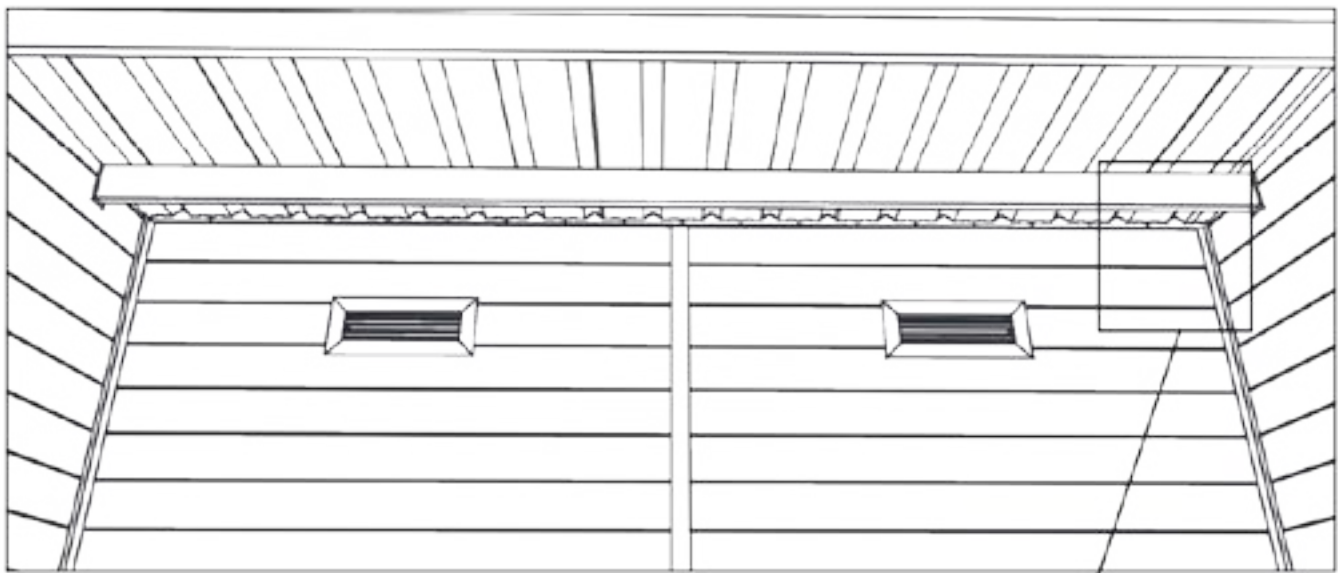

EN Insert, one after the other, the roof covers between the roof panel and the wall panel. With the help of the caulking gun, create a seal at the base, around the windows and the doors to insulate from rain (as shown in red).

FR Insérez, les uns après les autres, les bouchons de toit entre panneau de toit et panneau mural. A l'aide d'un pistolet, créez un joint à la base, autour des fenêtres et de la porte afin d'isoler de la pluie (comme illustré en rouge).

IMPORTANT

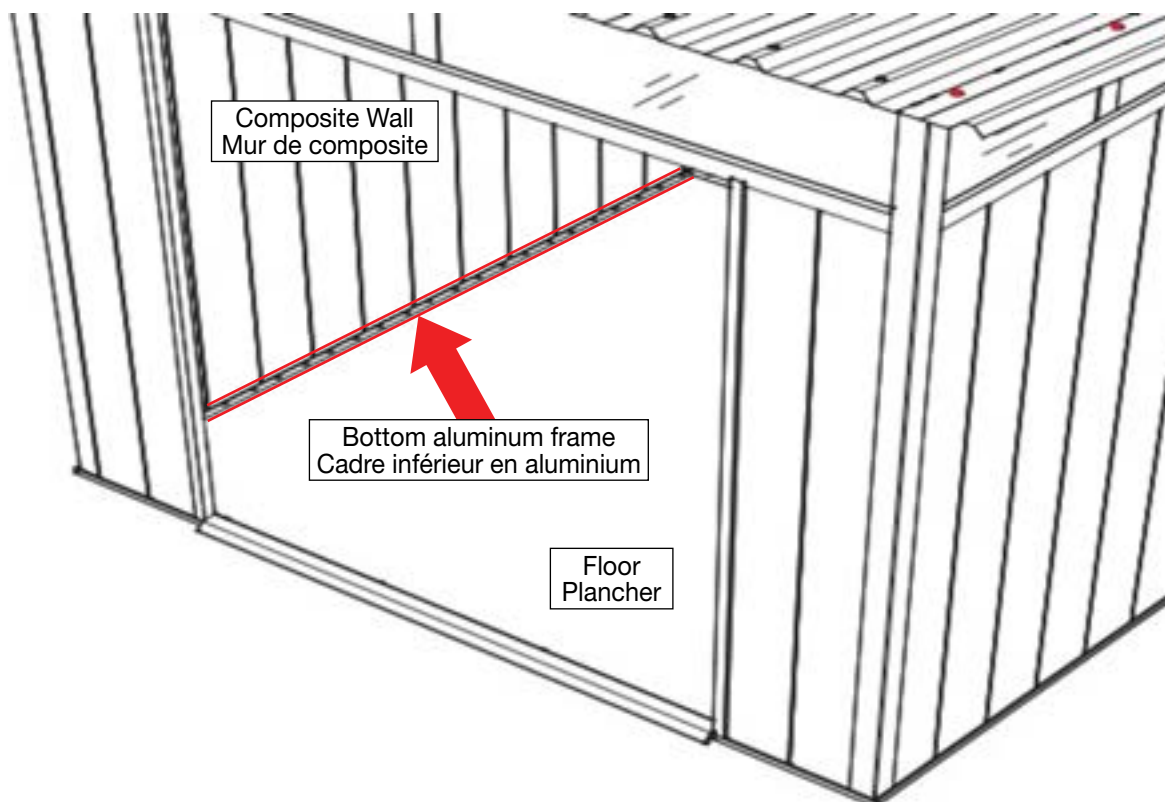

EN To prevent water infiltration issues, you must add a sealant at the bottom of the shed:

1. Perform a thorough cleaning of the shed: remove any dust and debris from the floor and ensure the floor is completely dry.
2. Apply a bead of sealant all around the interior of the shed between the floor and the lower aluminum frame (refer to page #10 in the installation guide).
3. Apply a bead of sealant all around the interior of the shed between the composite wall and the lower aluminum frame as well.
4. Apply a sealant from the floor upwards with a minimum of 4 inches in all corners.

It is recommended to use a sealant of the Flextra type (thermoplastic rubber-based).

FR Afin d'éviter les problèmes d'infiltration d'eau, vous devez ajouter un scellant dans le bas du cabanon :

1. Effectuez le nettoyage complet du cabanon : enlevez toute la poussière et les débris qu'il pourrait y avoir sur plancher, et s'assurer que le plancher soit complètement sec.
2. Faire un joint de scellant tout le tour à l'intérieur du cabanon entre le plancher (sol) et le cadre inférieur en aluminium (référez-vous à la page #10 du guide d'installation).
3. Effectuez également un joint de scellant tout le tour à l'intérieur du cabanon entre le mur en composite et le cadre inférieur en aluminium.
4. Effectuez un joint du plancher vers le haut avec un minimum de 4 pouces dans tous les coins.

Il est recommandé d'utiliser un scellant de type Flextra (thermoplastique à base de caoutchouc).



WARRANTY - GARANTIE



Scan the QR code to find out about all your shed's warranty in the **SUPPORT** section on the Fiberwood website.



Scannez le code QR pour découvrir tous les détails concernant la garantie de votre cabanon dans la section **SUPPORT** sur le site de Fiberwood.

For any problem with your shed, please contact us directly at: Toll Free : 888-360-1866

Pour tout problème avec votre cabanon, veuillez nous contacter directement au : Sans frais : 888-360-1866

829, boul. Industriel, Bois-des-Filion, QC, J6Z 4T3 – info@fiberwood.ca





829, Industriel Blvd, Bois-des-Filion, Quebec, Canada, J6Z 4T3
514-360-1866 / 888-360-1866
fiberwood.ca

**FOR ANY PROBLEM WITH YOUR SHED PLEASE CONTACT US DIRECTLY
POUR TOUT PROBLÈME AVEC VOTRE CABANON, VEUILLEZ NOUS CONTACTER DIRECTEMENT**